

## TODD WATER CONTROL UNIT 2100

The Todd Water Control Unit 2100 is an economical solution for the efficient management of water service during the embalming process. The WCU 2100 Comes complete with a hydro-aspirator, hot and cold-water embalming machine fill, and hot and cold water for the morgue table.



## FEATURES

Ultra-space-saving, counter-mounted version
Quick disconnects and 12-feet of tubing for aspirator and morgue table water
Custom fill spout riser heights, spout extension, and wall braces available upon request

## Specifications

Height of fill spout above counter; 21 3/4" standard, 15 3/4" and 26 3/4" available. Add 4" to all heights for clearance required for mounting under upper cabinets.
Weight: 15 lbs
Aspirator performance: 27-29# @ 65 psi.
All stainless steel housing and chrome fittings

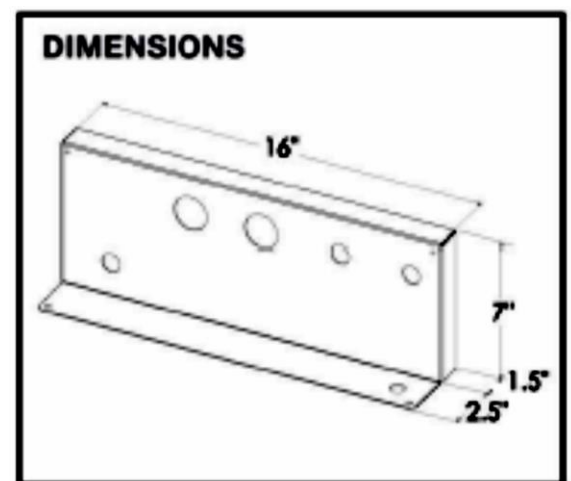

## TODD WATER CONTROL UNIT 2100 INSTALLATION

Unit is supplied pre-assembled and pre-plumbed, except for gooseneck spout
Provide 1" cold water supply an ½" hot water supply to angle stop.
Requires a minimum 1 ½" waste line with p-trap connected directly to facility waste line
Supplied with stainless steel mounting hardware, template, and installation requirements.
Install in accordance with all applicable codes.
Flush all plumbing lines prior to start-up

## AUXILLARY REQUIREMENTS FOR CODE COMPLIANCE

Reduced pressure backflow preventers required on cold and hot water lines.
Mark piping to Todd WCU 2100 as non-potable per plumbing code requirements.

## AUXILLARY REQUIREMENTS FOR PROPER ASPIRATOR OPERATION

1" high pressure cold water line to the preparation room
Continuously operating water pressure of 65 to 85 psi to aspirator
We recommend units be installed with a volume pressure control system.

TODD WATER CONTROL UNIT 2100

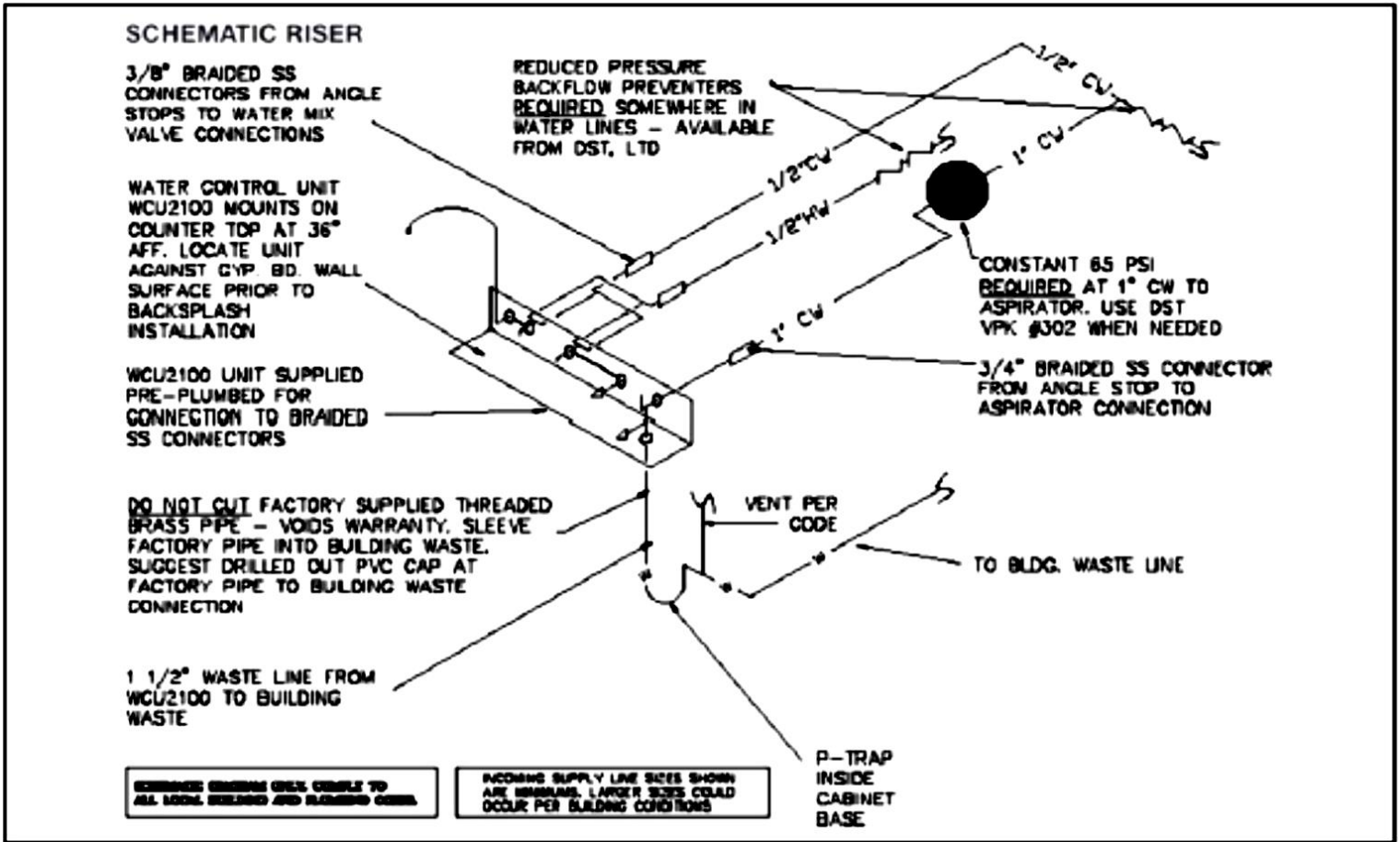

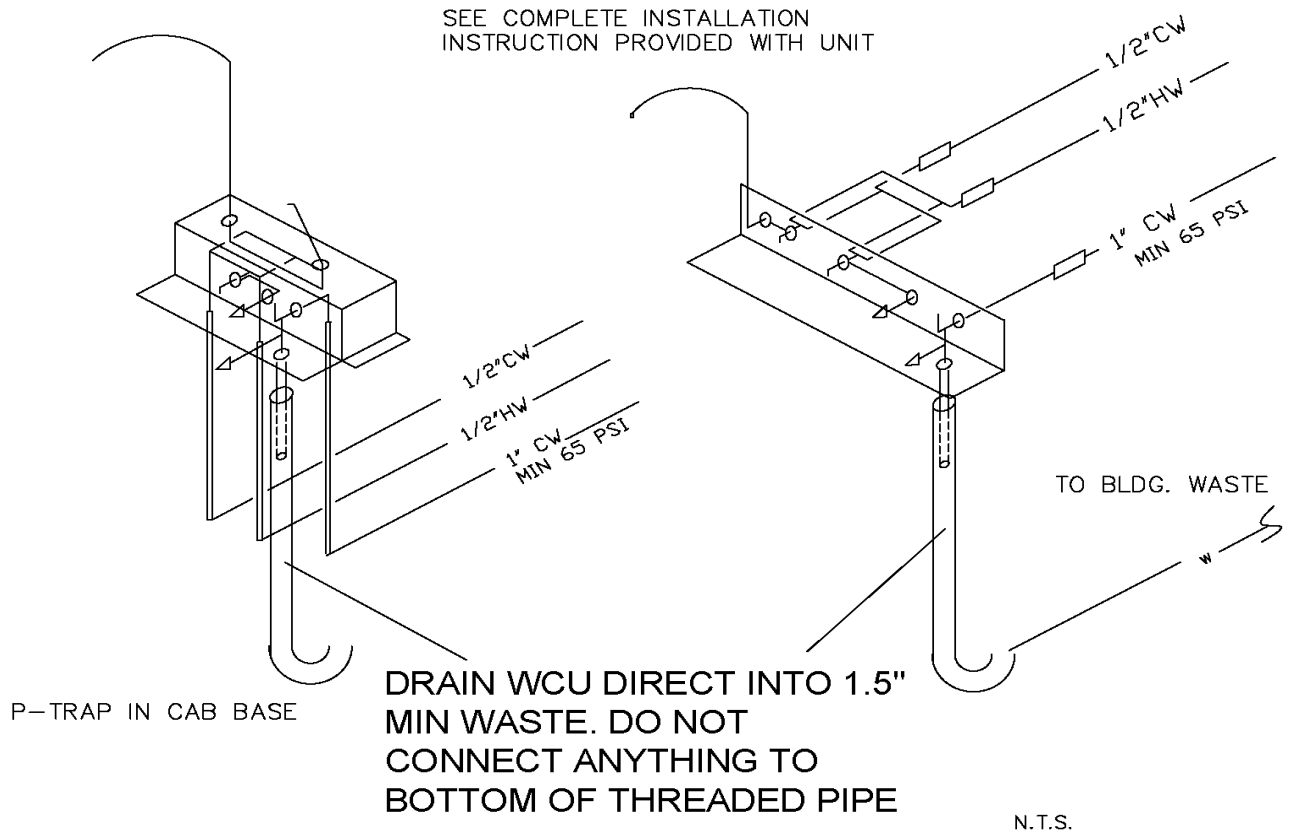

DO NOT CUT FACTORY SUPPLIED THREADED BRASS PIPE – VOIDS WARRANTY. SLEEVE FACTORY PIPE INTO 1½" BUILDING WASTE

DRAIN DIRECT INTO 1.5" MIN WASTE LINE FROM SUPPLIED THREADED PIPE DO NOT THREAD ANYTHING ONTO THE PIPE

## IMPORTANT NOTICE REGARDING WATER CONTROL UNIT WASTE LINE CONFIGURATION

DUNCAN STUART TODD LTD

V1-18-16