



TECHNICAL INFORMATION

TODD WATER CONTROL UNIT 4000

DST 222

The Todd Water Control Unit 4000 is an economical solution for the efficient management of water service during the embalming process. It is designed for installation on island table counters or other locations where the unit is visible from all four sides. The WCU 4000 comes complete with a hydro-aspirator, hot and cold water embalming machine fill, and hot and cold water for the morgue table.

FEATURES

Ultra space-saving

Island-table mounting version

All four sides constructed of 16-gauge stainless steel, with removable stainless steel back plate for easy access to plumbing connections

Quick-disconnects and 12' of tubing for aspirator and morgue table water

Custom fill spout riser height, spout extensions and wall braces available upon request

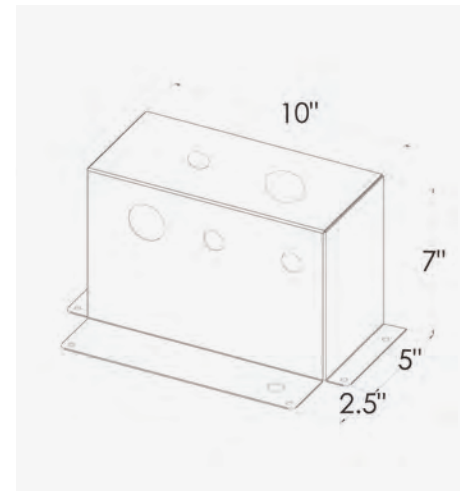

SPECIFICATIONS

Height of fill spout above counter: add 4" to all heights for clearance required when mounting under upper cabinets

Weight: 13 lbs

Aspirator performance: 27-29# @ 65psi

All stainless steel housing and chrome fittings

TODD WATER CONTROL UNIT 4000 DST 222

INSTALLATION

Unit is supplied pre-assembled and pre-plumbed, except for gooseneck spout

Provide 1" cold water supply to aspirator and .5" hot & cold water supply to angle stops

Requires minimum of 1.5" aspirator waste line with p-trap connected directly to facility waste line

Supplied with stainless steel mounting hardware, template, and installation requirements

Install in accordance with all applicable codes

Flush all plumbing lines prior to start-up

AUXILIARY REQUIREMENTS FOR CODE COMPLIANCE

Reduced pressure backflow preventers required on cold and hot water lines

Mark piping to Todd WCU 4000 as non-potable per plumbing code requirements

AUXILIARY REQUIREMENTS FOR PROPER ASPIRATOR OPERATION

1" high pressure cold water line to the preparation room

Continuously operating water pressure of 65 minimum psi to aspirator

We recommend units be installed with a Volume Pressure Control System, DST 302

TODD WATER CONTROL UNIT 4000 DST 222

SCHEMATIC RISER DIAGRAM - STAND ALONE WCU4000

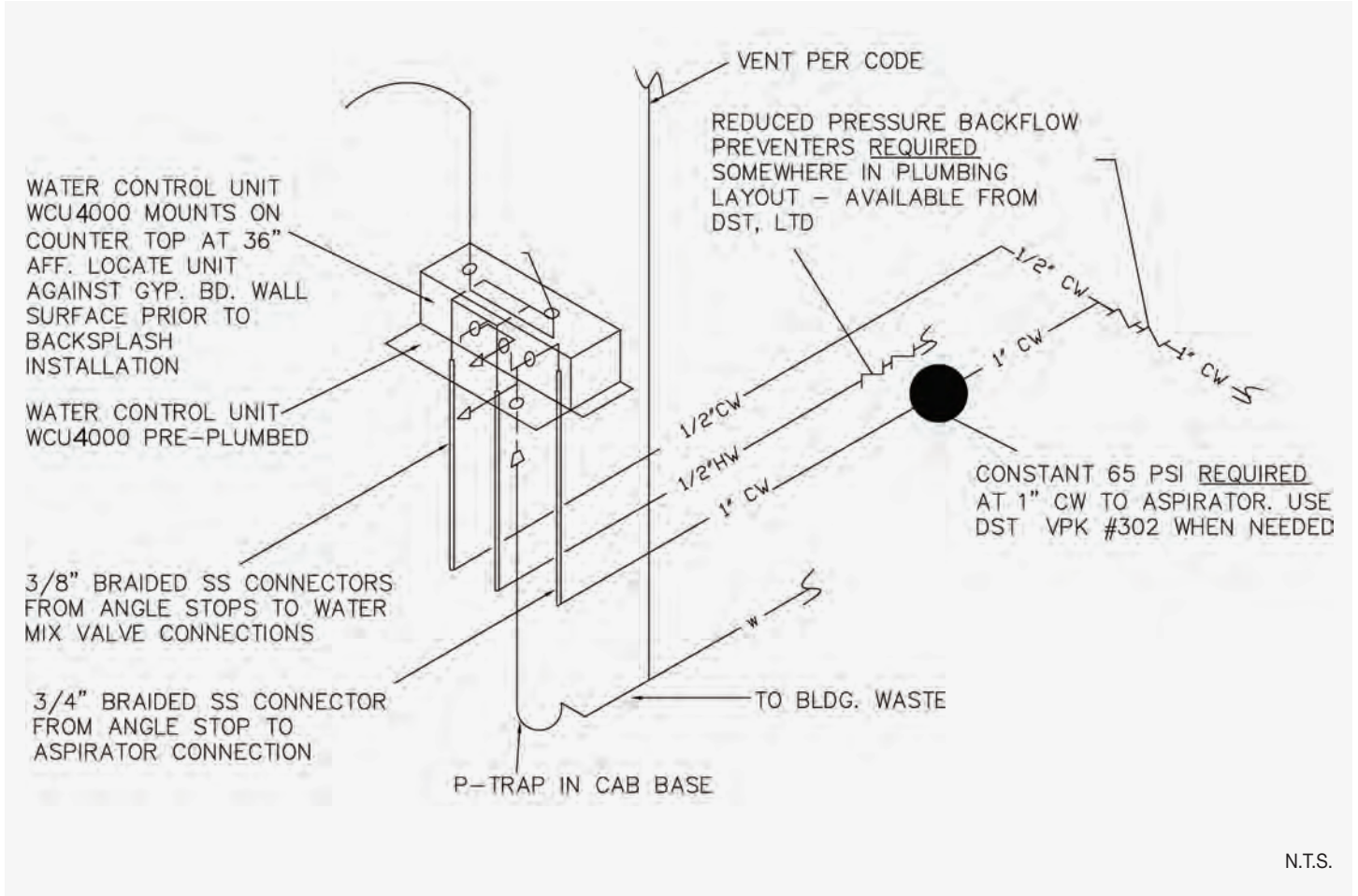

TODD WATER CONTROL UNIT 4000 DST 222

WATER CONTROL UNIT WASTE LINE CONFIGURATION

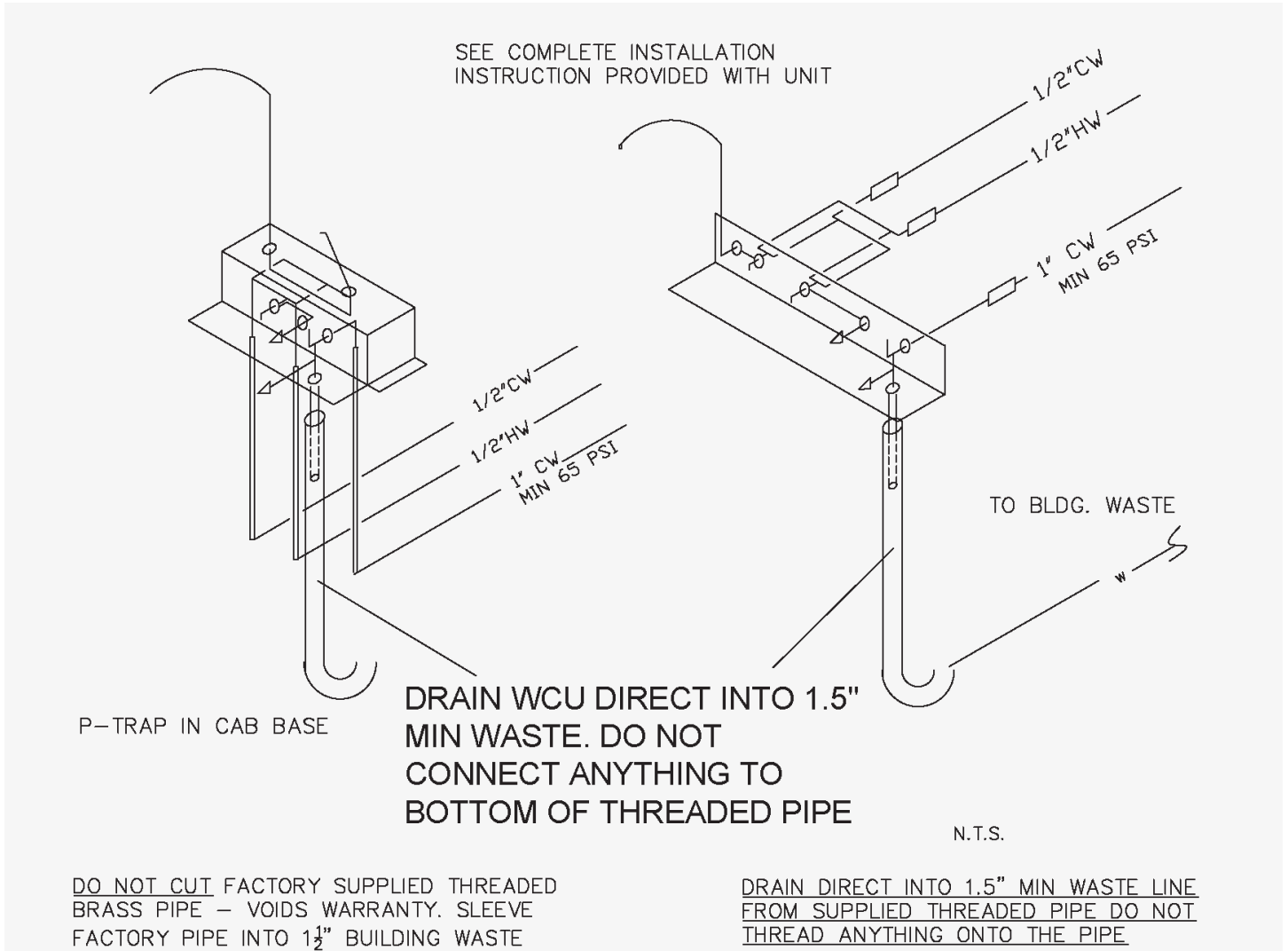

IMPORTANT NOTICE REGARDING WATER CONTROL UNIT WASTE LINE CONFIGURATION

v1-18-16