



## TECHNICAL INFORMATION

### TODD MORGUE TABLE RECEPTOR 5000

DST 216

The Morgue Table Receptor 5000 is a continuous rinsing rim direct drain system for waste removal at the foot end of the table.

## FEATURES

- Ultra space-saving, compact design fits easily into both new and retrofit projects
- Continuous incoming water supply keeps drain line clear and reduces airborne particulates
- Built-in pressure-reducing device helps maintain recommended PSI, easily removable if desired
- Cabinet mounted for easy floor cleaning
- Removable 3" round strainer sleeve with easy-lift handle captures cotton and other large waste

## SPECIFICATIONS

- Manufactured from 16-gauge stainless steel
- Weight: 10 lbs
- Recommended mounting height: 26" above floor to top of the unit

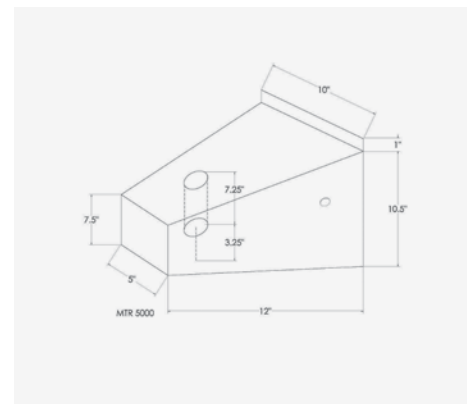



THE PREPARATION ROOM SPECIALISTS | SINCE 1991

---

**TODD MORGUE TABLE RECEPTOR 5000** DST 216

## INSTALLATION

Unit is pre-plumbed and ready to mount with 4 fasteners, supplied

Mount unit on a 32" wide fixed panel

One .5" flexible cold water connection from angle stop

One 2" waste line with p-trap connected directly to facility waste line

Supplied with mounting hardware, template, and installation instructions

Install in accordance with all applicable codes

Clean out all plumbing lines prior to startup

## REQUIREMENTS FOR CODE COMPLIANCE

Reduced-pressure backflow preventers required on cold water line

Mark piping to Todd MTR 5000 non-potable per plumbing code requirements

## TODD MORGUE TABLE RECEPTOR 5000 DST 216

### SCHEMATIC RISER DIAGRAM - TODD MTR 5000 DST 216

