

PrepAir600w

Heat Recovery Ventilator Product Information

The PrepAir600w

PrepAir Environmental Control Modules are the first fully integrated HVAC systems that have been designed specifically to produce the conditions necessary to meet OSHA specifications in preparation rooms used in the funeral industry. The unique heat recovery module minimizes operation cost and maximizes personal comfort. A variety of options such as cooling, defrost, electrical or hot water heating, and remote controls are available to meet your design requirements.

How it works:

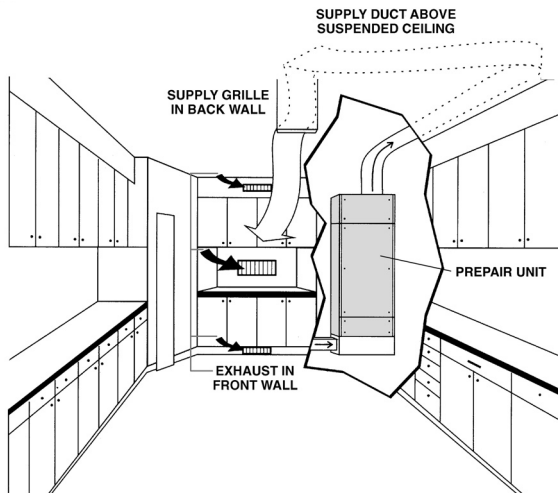
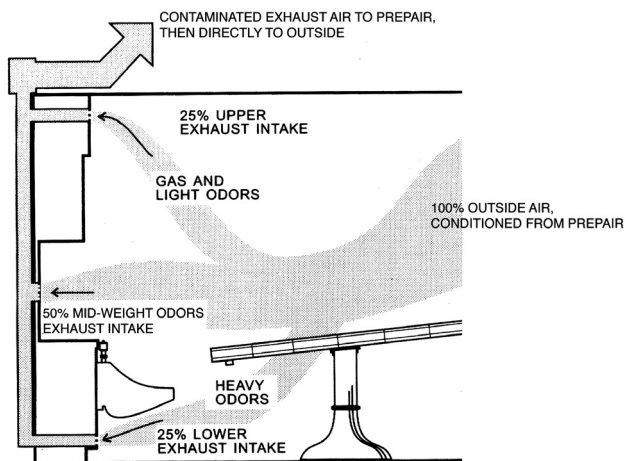

Typical Preparation Room Layout



PrepAir600w Dimensional Drawing

TOP VIEW WITH DUCTED SUPPLY PLENUM

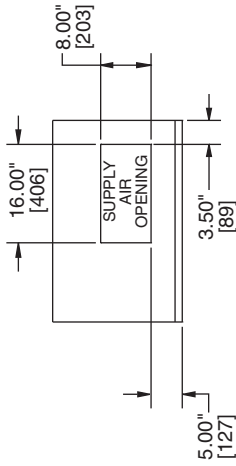

NOTES:

- 1) Dimensions in [] are in millimeters
- 2) Direction of airflow
- 3) Factory supplied outdoor air louvres require wall penetrations as shown for air duct opening sizes
- 4) Maintenance: Allow minimum 24" [610] clearance for front access

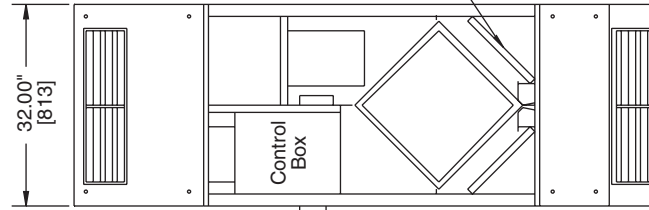

FRONT VIEW

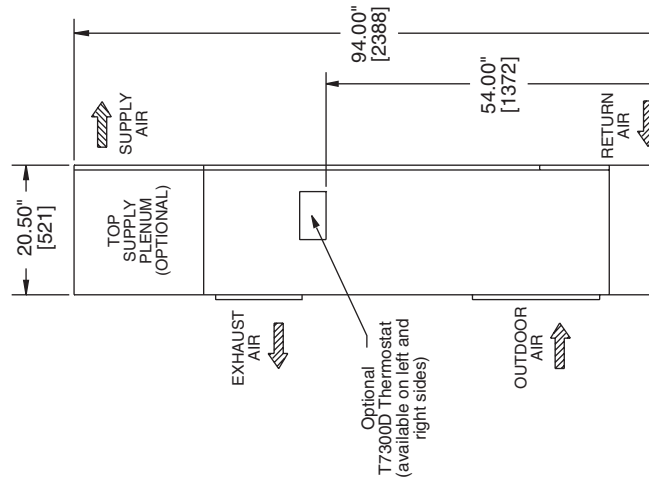

LEFT SIDE VIEW

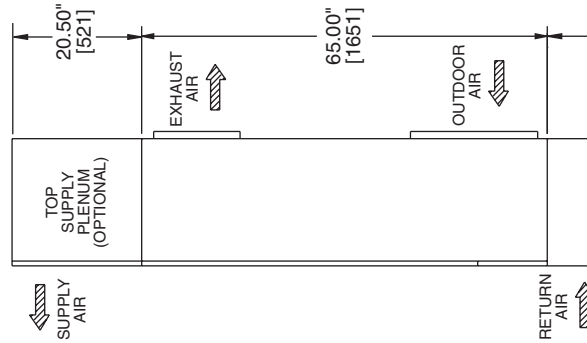

RIGHT SIDE VIEW

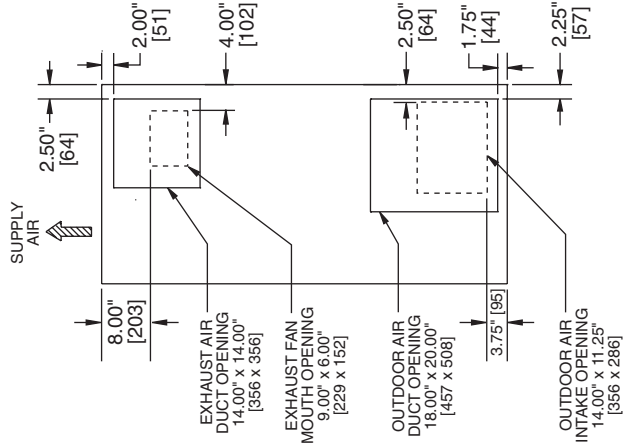

BACK VIEW

PrepAir600w Specifications and Ratings

Total Assembled Weight: 250 lbs [114kg]	Insulation: R-4 foil face
Intake Duct from Outside: 18" x 20" [457 x 508mm]	Ventilation Air Volume: 300 - 600 cfm
Exhaust Duct to Outside: 14" x 14" [356 x 356mm]	All Electrical Data: See chart below
Supply Air Duct: Without Top Plenum	Supply and Exhaust Blower Motors:
Electric: 8" x 10" [203 x 254mm]	H.P.: 1/2
Hydronic: 12" x 13" [305 x 330mm]	RPM: 1075/600
With Top Plenum (opt) 16" x 8" [406 x 203mm]	Bearings: Shielded ball bearing
	Type: PSC
Filters: 30 ppi reticulated foam 14" x 18" x 1" [356 x 457 x 25mm]	Fan Speed Control: Low and high
Cabinet: 20 ga. metal	Flat Plate Air-to-Air Heat Exchanger Surface Area:
	Poly: 346 sq. ft
	Type/Material: Crossflow Polypropylene

PrepAir600w Electrical Data

Amount of Heat	MCA	MOP	Btu/hr	A/C Option	
				1 1/2 Ton	
				kW	Btu/hr
2.5 kW	32.3	35	8,533	5.3	18,000
5.0 kW	47.3	50	17,065	5.3	18,000
7.5 kW	65.2	70	25,598	5.3	18,000
10.0 kW	77.5	80	34,130	5.3	18,000

230 VAC PrepAir600w Electric Heat

Amount of Heat	MCA	MOP	Btu/hr	A/C Option	
				1 1/2 Ton	
				kW	Btu/hr
2.5 kW	31.0	35	8,533	5.3	18,000
5.0 kW	41.5	50	17,065	5.3	18,000
7.5 kW	58.1	70	25,598	5.3	18,000
10.0 kW	71.7	80	34,130	5.3	18,000

120 VAC PrepAir600w Hydronic Heat

Amount of Heat	MCA	MOP	kW	Btu/hr	A/C Option	
					1 1/2 Ton	
					kW	Btu/hr
No heat	17.3	25	0	0	5.3	18,000
25 MBH H ₂ O coil	17.3	25	6.7	23,000	5.3	18,000
50 MBH H ₂ O coil	17.3	25	10.8	37,000	5.3	18,000

PrepAir600w Coil Dimensional Data

DX COOLING

CONNECTION TABLE		CONNECTION SIZES	
(A)	Field power supply outlet	7/8"	
(B)	Supply	3/8" (SWEAT)	
(C)	Drain	3/4" (SWEAT)	
(D)	Suction	3/4" (SWEAT)	

TOP VIEW
WITHOUT SUPPLY PLENUM

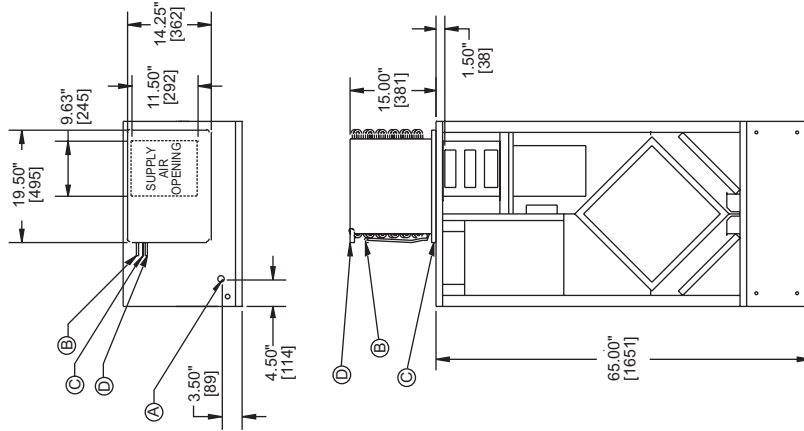

FRONT

NOTE: Drain for condensate will have to be installed out the bottom of the unit.

ELECTRIC HEAT

CONNECTION TABLE		CONNECTION SIZES	
(A)	Field power supply outlet	7/8"	

TOP VIEW
WITHOUT SUPPLY PLENUM

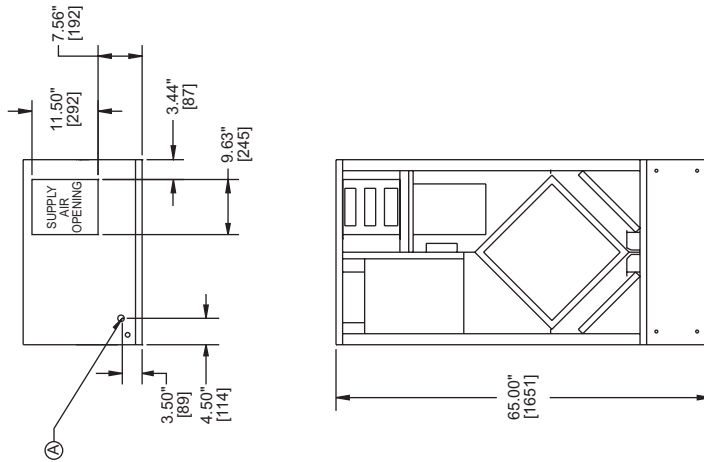

FRONT

25/50 MBTU HYDRONIC

CONNECTION TABLE		CONNECTION SIZES	
(A)	Field power supply outlet	7/8"	
(B)	Coil connection	7/8" (SWEAT)	
(C)	Coil connection	7/8" (SWEAT)	

TOP VIEW
WITHOUT SUPPLY PLENUM

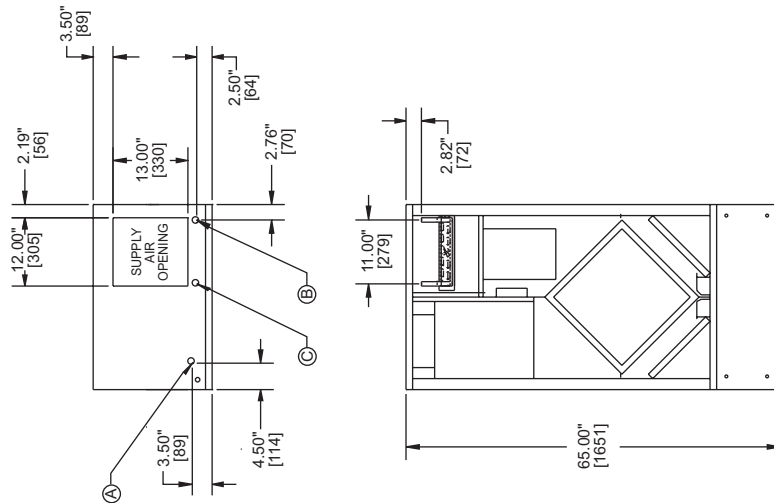

FRONT